

DCG250-12S | Volvo TAD-881-VE (185 kW) EU5 / T4F + Dana TE-14400 | Duplex, clear view, free lift - LH 3500

Lifting data	DCG250-12S
Lifting capacity, rated (kg)	25000
Lifting speed, unloaded – at 70% of rated load (m/s)	0,44 - 0,42
Lowering speed, unloaded – at rated load (m/s)	0,34 - 0,40
Driving data	
Gradeability max., unloaded – at rated load (%)	101 - 44
Gradeability at 2 km/h, unloaded – at rated load (%)	63 - 31
Drawbar pull, max. (kN)	230
Engine	
Manufacturer / model	Volvo / TAD-881-VE
Fuel / type of engine	Diesel / 4 stroke
Emission stage / approval	EU Stage V / EPA Tier 4 Final
Number of cylinders / displacement (liter)	6 / 7.7
Power rated @ revs, ISO 3046 (kW@rpm)	185 / 1600 - 2200
Max. rpm in machine	2000
Torque max @ revs, ISO 3046 (Nm@rpm)	1150 / 1100 - 1500
Alternator, type - power (W)	AC - 3080 (28V x 110A)
Starting battery, voltage - capacity (V – Ah)	2x12 - 145
Fuel consumption, normal driving (l/h)	8 - 11
DEF consumption, normal driving (% of diesel)	4 - 6
Transmission	
Manufacturer / model	Dana / TE14, Lock up as option
Clutch, type	Torque converter
Gearbox, type	Hydrodynamic Powershift
Number of gears, forward - reverse	4 - 4 / optional Lock-Up
Driving axle, manufacturer / type	Kessler D91 / Differential and hub reduction
Wheels	
Type	Pneumatic
Dimension, front – rear (inch)	14.00x24 – 14.00x24
Number of wheels, front – rear (*driven)	4* - 2
Pressure (MPa)	1.0
Miscellaneous	
Steering system, type – maneuvering	Hydraulic servo - Steering wheel
Service brake system, type – affected wheels	Oil cooled disc brakes (Wet disc brakes) - Drive wheel
Parking brake system, type – affected wheels	Dry, spring activated disc brakes - Drive wheel
Max. hydraulic pressure (MPa)	22.0
Noise level EN12053 with ECO modes - equivalent inside cabin LpAZ (dB(A))	72
Noise level EN12053 with ECO-modes - equivalent outside cabin LwAZ (dB(A))	109
Fuel volume (l)	375
AdBlue volume (l)	15
Hydraulic oil volume (l)	330

Illustrations does not correspond to the actual configured lift truck.

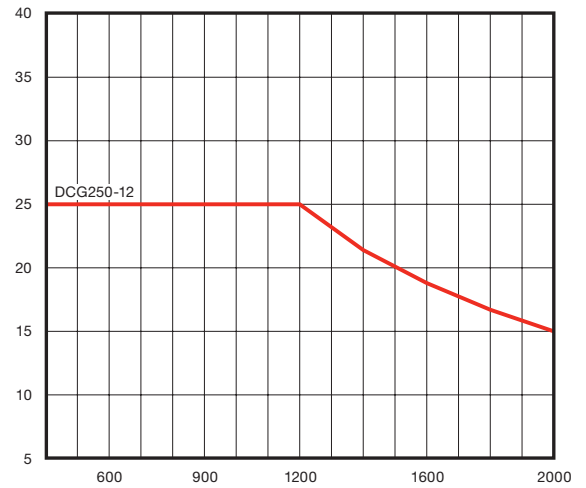
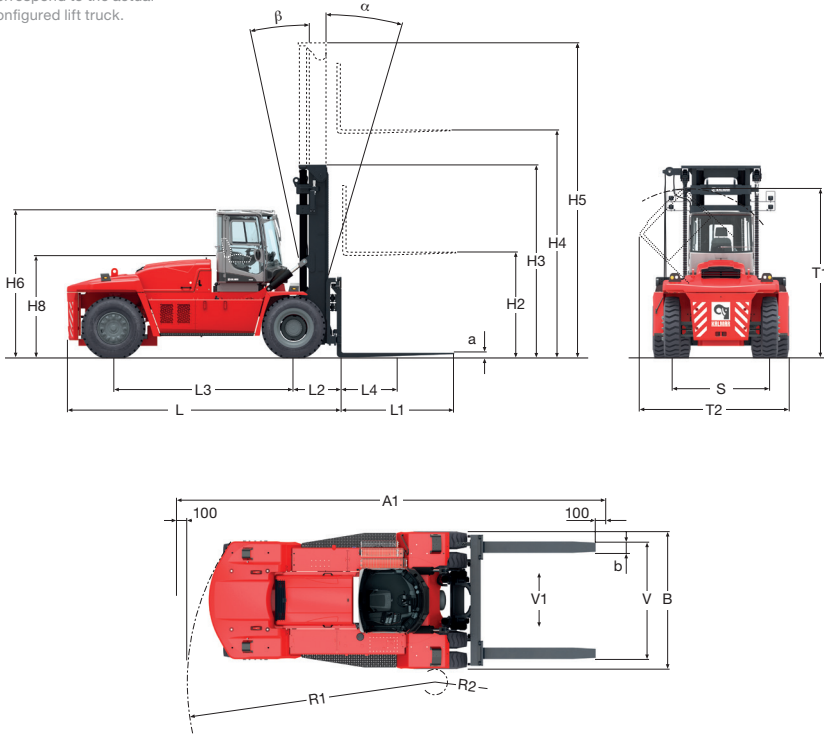

Dimensions

Length of truck (mm)	L	6090
Width of truck (mm)	B	3050
Height of basic machine (mm)	H6	3270
Height of seat (mm)	H8	2150
Distance between centre of front axle – front face of fork arm (mm)	L2	1070
Wheelbase (mm)	L3	4000
Load centre (mm)	L4	1200
Track (c-c), front – rear (mm)	S	2200 - 2200
Turning radius, outer – inner (mm)	R1-R2	5600 - 425
Ground clearance, min. (mm)		300
Max. height when tilting cab (mm)	T1	3800
Max. width when tilting cab (mm)	T2	3700
Min. aisle for 90° stacking with forks (mm)	A1	9270
Lifting height (mm)	H4	3500
Mast height, min. (mm)	H3	3670
Mast height, max. (mm)	H5	5420
Free lift (mm)		1750
Tilting of mast, forward - backward (°)	α - β	5 - 10
Fork width (mm)	b	250
Fork thickness (mm)	a	110
Length of forkarm (mm)	l	2400
Width across fork arms, max. - min. (mm)	V	2700 - 800
Sideshift \pm at width of across fork arms (mm)	V1-V	557 - 1585

The design and materials specification are subject to alternation without prior notice.
Tolerances according to K-standard 95430.0008/0009



Kalmar (Nasdaq Helsinki: KALMAR) is moving goods in critical supply chains around the world, with the vision to be the forerunner in sustainable material handling equipment and services. The company offers a wide range of industry shaping heavy material handling equipment and services to ports and terminals, distribution centres, manufacturing and heavy logistics. Headquartered in Helsinki, Finland, Kalmar operates globally in over 120 countries and employs approximately 5.000 people. In 2023, the company's sales on a carve-out basis totalled approximately EUR 2,0 billion.
www.kalmarglobal.com

Kalmar Solutions AB
Movägen 1
SE-341 32, Ljungby, Sweden
tel. +46 372 260 00
www.kalmarglobal.com